

# Institute for STEM Education



Stony Brook University  
College of Engineering  
and Applied Sciences

## *Build Your Own Home Security System*

Student Lab Guide



Engineering Teaching Laboratory

Name \_\_\_\_\_ Date \_\_\_\_\_

Lab Partner(s) \_\_\_\_\_

## **NEW TERMS**

Electric Circuit: Electric circuits are paths for transmitting electric current, or moving electricity. Such circuits allow electricity to be used to provide power to lights, appliances, and many other devices

Capacitor: a device used to store electric charge. It is similar to a battery except it stores energy instead of providing new energy. These are used to amplify power supplies and filter out electronic ripples.

Resistor: a device that is designed to resist the passage of an electric current.

Phototransistor: a transistor that is sensitive to light. A transistor is a semiconductor device that can be either used as an amplifier of a signal or as a switch. In this design the phototransistor, Q1, will be used as a switch.

Integrated Circuit (IC): An IC is a collection of electronic components (resistors, transistors, capacitors, etc.) all stuffed into a tiny chip, and connected together to achieve a common goal. In this design, the IC will function as a timer.

Printed Circuit Board (PCB): a board that mechanically supports and electrically connects electronic components using conductive tracks, pads, and other features etched into the nonconductive board in copper. Components are generally soldered onto the PCB.

Terms to be familiar with:

Circuits  
Series  
Parallel  
Voltage  
Electricity  
Conductors  
Insulators

## INTRODUCTION

Current, voltage, and resistance are related through Ohm's Law ( $V = I * R$ ). Simply put, a current is defined as a voltage across a known resistance and a voltage is defined as the current through a known resistance. Putting together voltage, current, and resistance develops a circuit. Circuits are very powerful tools used all throughout our daily lives. They are used to turn on our lights in the house and power our electronic devices. Engineers use simplified drawings called schematic diagrams to show how a circuit is connected. The circuit diagrams have a code to show different components, like resistors (zigzag) and capacitors (double lines). A schematic for the circuit being built in this lab is shown here.

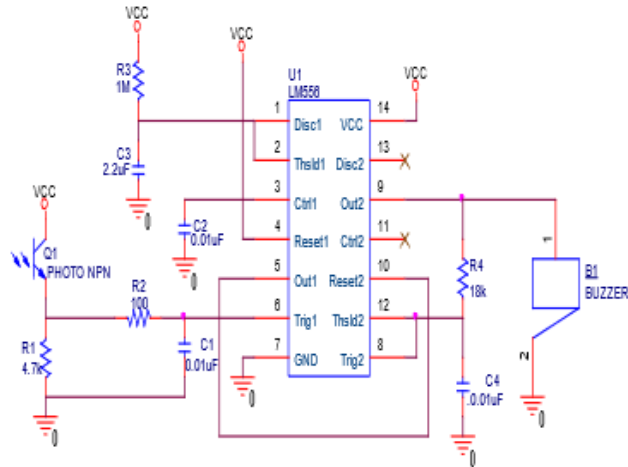

Circuits are composed of various components that contribute to its functionality. They all need a power source to function and have different combinations of resistors and capacitors to determine what the output signal will be. The output can be regulated by how many of these components are present, as well as the components' values. This will lead to different circuits making different signals.

A home security system is one of the simplest and most interesting circuits for electrical engineering novices. In this lab activity, you will make your own home security system that will use a phototransistor and timer to detect security problems. Theft attempt and other security threats can be controlled by using this simple circuit. This circuit can be implemented in your own private room or even your closet. The system in this design will function as follows:

1. The capacitor is charging.
2. When light is blocked, the trigger goes low.
3. Reset pin goes high and enables the second timer to control the buzzer frequency.
5. Buzzer goes on.
6. When the capacitor voltage reaches  $2/3VCC$ , the discharge pin activates and the capacitor begins to discharge.
7. The capacitor is discharging.
8. When the capacitor voltage reaches  $1/3 VCC$  (close to  $\sim 0V$ ) the threshold pin will indicate that the timing cycle is over and sets the reset pin to zero.
9. Buzzer will stop.

## PROCEDURE

### A) Orientation Critical

The following components must be installed in a particular direction. After installing the component, solder it down and trim the leads if necessary.



*Figure 1*

1. Place the circuit board as shown in Figure 1. All of the components must be installed on this side of the board. The orientation references (right, left, top and bottom) throughout this procedure refer to the board in this position.

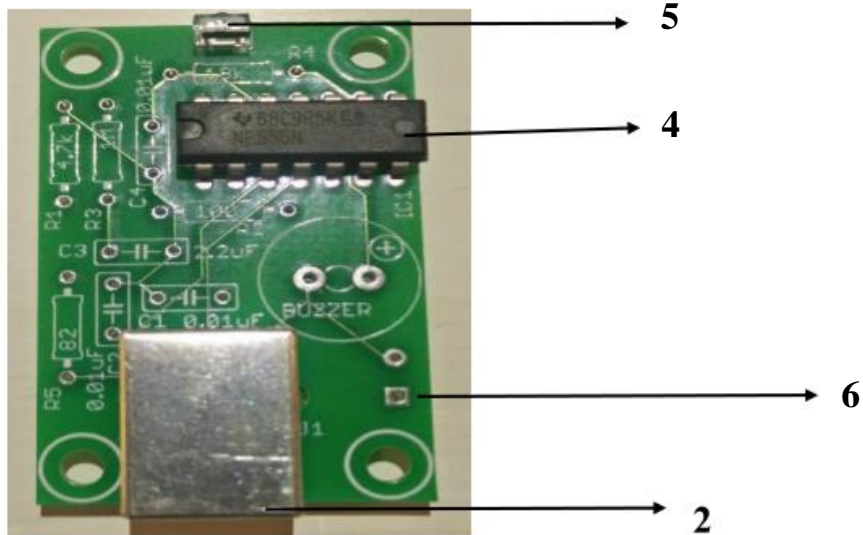

*Figure 2*

2. Install the USB receptacle as shown in Figure 2. Snap the component into place and solder it in.

3. Locate the 14 pin NE556N timer chip (14 legged bug). Notice that the pins on one side of the chip are not parallel with the other side. Place the chip on a flat surface and bend all of the pins perpendicular to the chip body.

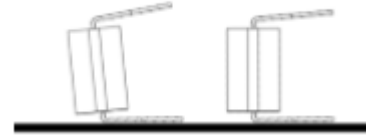

4. Install NE556N as shown in Figure 2. **Note** that this part has a small indentation on one side. The side with the indentation must be positioned with the indentation toward the left as shown in the figure. The indentation will match a similarly shaped mark on the printed circuit board.

5. Locate the phototransistor Q1 (clear two-legged component). **Note** that a black rectangle is visible on one side of the component and the other side has a tiny clear bump. The clear bump is a lens. Install the component on the circuit so that the bump aligns with the pattern on the circuit board. This will leave the lens facing away from the circuit board and the black rectangle facing the center of the board as shown in Figure 2.

6. Install laser light, with the red wire going into the square hole and blue wire going to the round hole, as shown in Figure 2.

## B) Value Critical

The rest of the components can be installed either way around, but you must be very careful to install the right component in the right holes. Check the resistor color codes carefully and ask for assistance if you are not sure Also, the different capacitor values may look very similar.

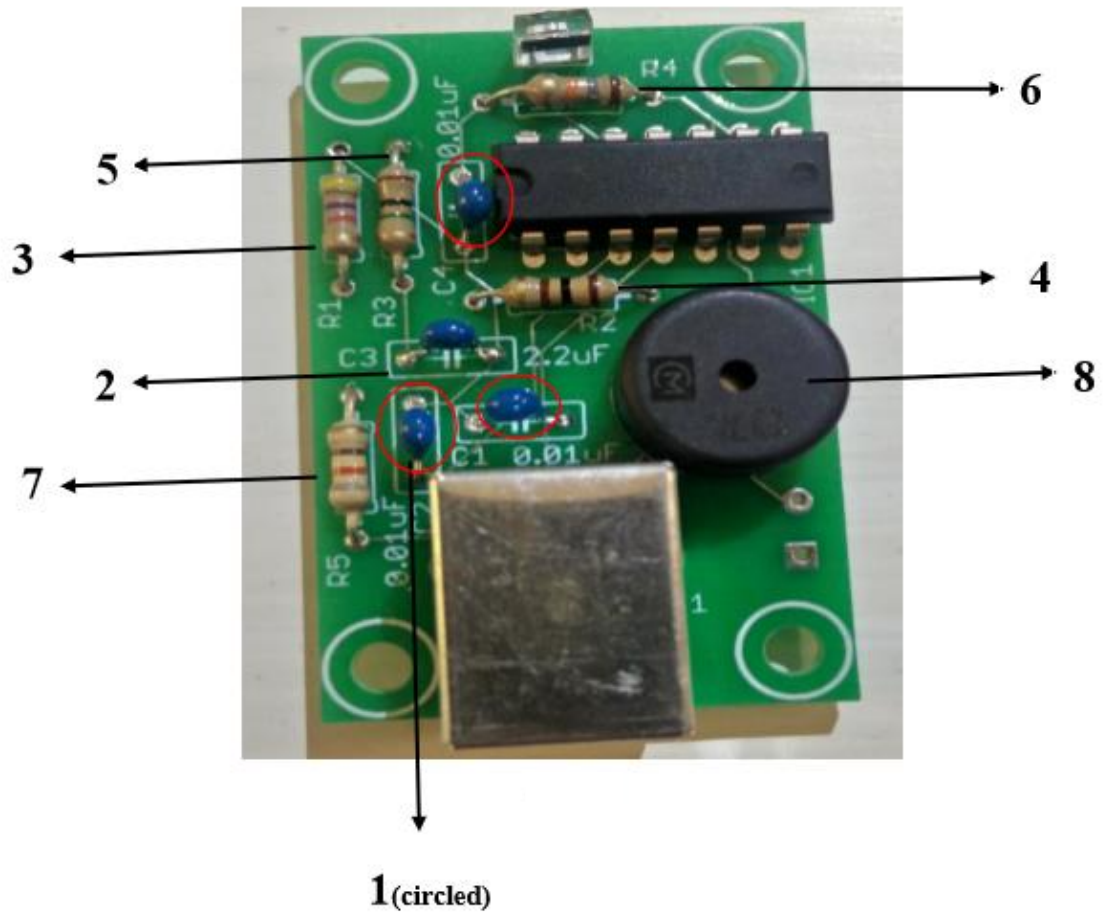

Figure 3

1. Install capacitor C1, C2, C4 (blue blob= 0.01uF) into the locations marked C1, C2, and C4.
2. Install capacitor C3 (blue blob= 2.2uF) into the C3 location.
3. Install 4.7 k $\Omega$  resistor R1 (**yellow, violet, red, gold**) as shown.
4. Install 100  $\Omega$  resistor R2 (**brown, black, brown, gold**) as shown.
5. Install 1 M $\Omega$  resistor R3 (**brown, black, green, gold**) as shown.

6. Install 18 k $\Omega$  resistor R4 (**brown, grey, orange, gold**) as shown.
7. Install 220 $\Omega$  resistor R5 (**red, red, brown, gold**) as shown.
8. Install the buzzer B1. This component can be installed either way around.
9. Insert the laser diode into the holder. Press the laser in until the metal body is completely inside the holder. Place the laser caution sticker on the laser holder as shown.

### **C) Project Testing**

Power for this project can be provided by a USB charger or USB computer port. You will need a cable with a USB type 'B' end to fit the receptacle. These cables are often used for wired printers. To implement this alarm system for home/room, you have to provide an optical path around your home/room, with your laser beam!

Please go to the test station to test if your alarm system is working. Make sure to ask the teacher for assistance and guidance in testing the design.

**Questions:**

1. When the light is blocked, how long is the buzzer on for? Show your calculation.

2. What is the value of the frequency at which the buzzer makes a sound at? Show your calculation.

3. What is the function of a resistor in a circuit?

---

---

---

4. What is the function of a capacitor in a circuit?

---

---

---

5. What are photo transistors and how are they used in our design?

---

---

---

6. Electrical energy was transformed into \_\_\_\_\_ energy.

7. Was energy conserved in our design?

---

---

---

8. Is the amount of energy in the universe increasing, decreasing, or remaining the same?  
How is that possible? Why does the United States spend so much money for oil then?

---

---

---

9. Is it possible to determine the electrical energy in a circuit?

---

---

---

**Calculations:**

Period and frequency measurements: The time the buzzer goes ON for depends on resistor, R3, and capacitor, C3.

$$\text{Period } T = R_3 C_3 (\ln 2)$$

When the light is blocked, how long is the buzzer on for?

We know that a frequency = 1/Period. In our circuit the period depends on the values of the resistors and capacitors. In our design the frequency of the buzzer depends on both R4 and C4.

$$\text{Frequency} = 1 / (2(R_4 C_4 (\ln 2)))$$

What is the value of the frequency at which the buzzer makes sound?